



A division of Metropolitan Industries, Inc.



Ion[®]

**3 YEAR
WARRANTY**



Digital Level Control Switch

- Rated for use in both sump and sewage pump applications
- Solid state sensing technology with no moving parts to wear or fail
- Will work with any 115 volt pump up to 15 amps
- Longer pumping differential means it will pump more water less frequently
- 10 and 20 foot cord options are available



Suite 1095 #3 9899-112 ave
Grande Prairie AB Canada T8V 7T2
866-445-3984 www.NextStarTech.com

Patent No. 8,591,198,
9,033,686 and 9,680,401

Assembly View

1. Cord strain relief follower
2. Mounting arm screw
3. Switch mounting arm
4. Top housing
5. Control and logic boards
6. Switch bracket
7. Strain gauge
8. Pressure plate
9. Diaphragm with integrated o-ring gasket
10. Diaphragm guard

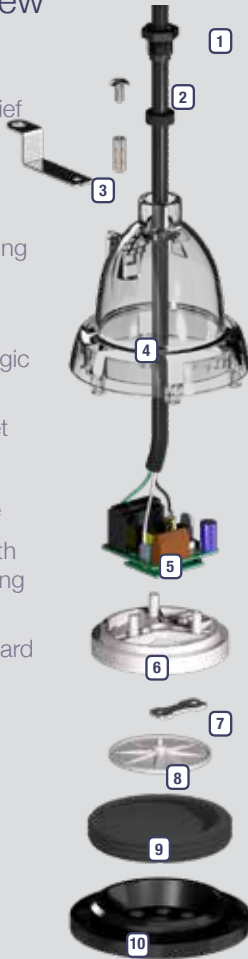

Switch Dimensions

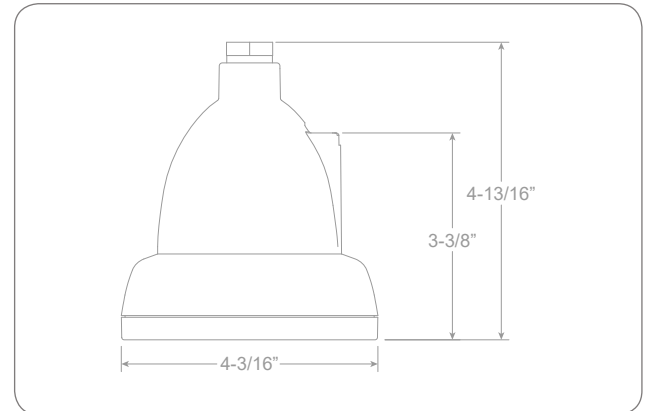

Piggyback Plug Illustration

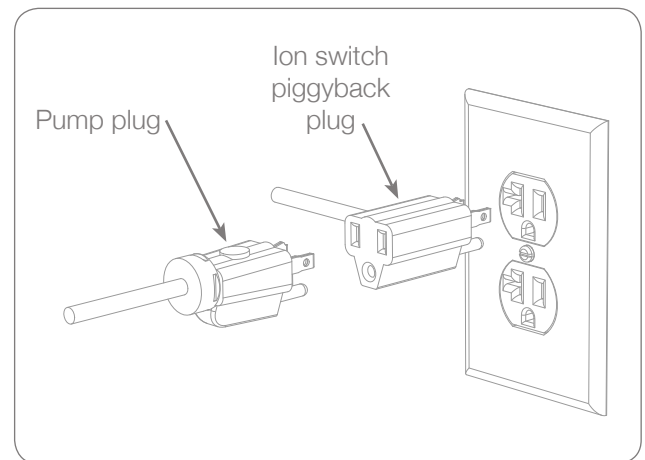

System Specifications

- Type of Application: Sump and sewage
- Voltage: 115 volt
- Amp Rating: 13 FLA, 15 amp max
- Power Cord: 10' or 20'

- Pump Range: 6" or 8.5"
- 3 year warranty
- Part Number (Sump): iN-006-010-10PA-B
- Part Number (Sewage): iN-085-010-10PA-B